

All dimensions are imperial unless stated.

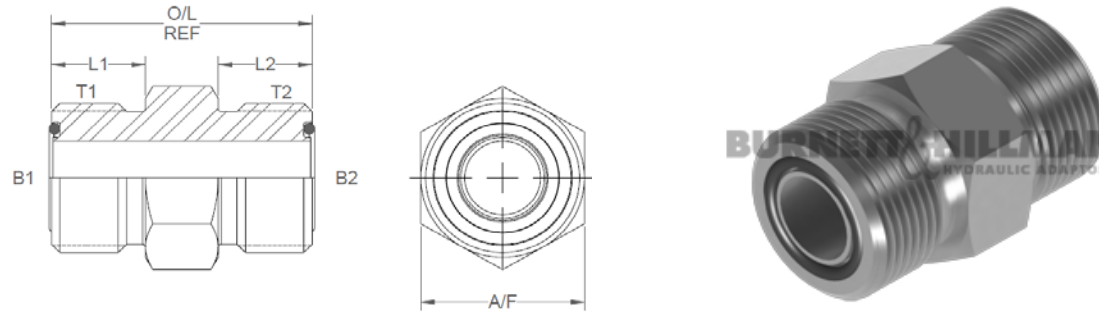

	T1	T2	B1	B2	L1	L2	O/L	A/F
9305-04-04	9/16	9/16	0.172	0.172	0.386	0.386	1.09	0.625
9305-04-06	9/16	11/16	0.172	0.172	0.386	0.441	1.167	19mm
9305-04-08	9/16	13/16	0.172	0.378	0.386	0.504	1.27	0.875
9305-06-06	11/16	11/16	0.25	0.25	0.441	0.441	1.232	19mm
9305-06-08	11/16	13/16	0.25	0.25	0.441	0.504	1.33	0.875
9305-08-08	13/16	13/16	0.378	0.378	0.504	0.504	1.39	0.875
9305-08-10	13/16	1	0.378	0.492	0.504	0.61	1.58	27mm
9305-08-12	13/16	1-3/16	0.378	0.609	0.504	0.67	1.694	1.25
9305-08-16	13/16	1-7/16	0.378	0.811	0.504	0.689	1.753	1.5
9305-10-10	1	1	0.492	0.492	0.61	0.61	1.69	27mm
9305-10-12	1	1-3/16	0.492	0.609	0.61	0.67	1.79	1.25
9305-10-16	1	1-7/16	0.484	0.811	0.61	0.689	1.859	1.5
9305-12-12	1-3/16	1-3/16	0.609	0.609	0.67	0.67	1.86	1.25
9305-12-16	1-3/16	1-7/16	0.609	0.811	0.67	0.689	1.919	1.5
9305-12-20	1-3/16	1-11/16	0.609	1.024	0.67	0.689	1.99	1.75
9305-16-16	1-7/16	1-7/16	0.811	0.811	0.689	0.689	1.939	1.5
9305-16-20	1-7/16	1-11/16	0.811	1.024	0.689	0.689	2.018	1.75
9305-16-24	1-7/16	2	0.811	1.26	0.689	0.689	2.087	55mm
9305-20-20	1-11/16	1-11/16	1.024	1.024	0.689	0.689	2.018	1.75
9305-24-24	2	2	1.26	1.26	0.689	0.689	2.078	55mm

DESIGN DETAILS AND SPECIFICATIONS SUBJECT TO CHANGE WITHOUT PRIOR NOTICE - Whilst every effort has been made to ensure the accuracy of the information supplied herein, Burnett & Hillman cannot be held responsible for any errors or omissions (E&OE)

A/F dimensions are imperial unless stated.

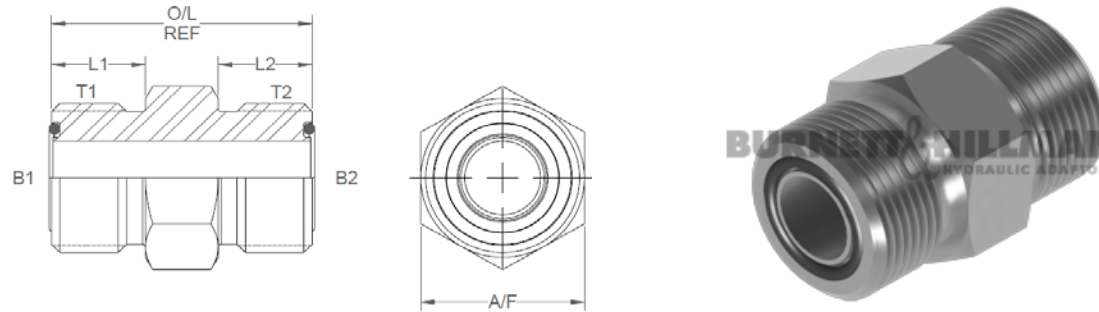

	T1	T2	B1	B2	L1	L2	O/L	A/F
9305-04-04	9/16	9/16	4.37	4.37	9.8	9.8	27.69	0.625
9305-04-06	9/16	11/16	4.37	4.37	9.8	11.2	29.64	19mm
9305-04-08	9/16	13/16	4.37	9.6	9.8	12.8	32.26	0.875
9305-06-06	11/16	11/16	6.35	6.35	11.2	11.2	31.29	19mm
9305-06-08	11/16	13/16	6.35	6.35	11.2	12.8	33.78	0.875
9305-08-08	13/16	13/16	9.6	9.6	12.8	12.8	35.31	0.875
9305-08-10	13/16	1	9.6	12.5	12.8	15.49	40.13	27mm
9305-08-12	13/16	1-3/16	9.6	15.47	12.8	17.02	43.03	1.25
9305-08-16	13/16	1-7/16	9.6	20.6	12.8	17.5	44.53	1.5
9305-10-10	1	1	12.5	12.5	15.49	15.49	42.93	27mm
9305-10-12	1	1-3/16	12.5	15.47	15.49	17.02	45.47	1.25
9305-10-16	1	1-7/16	12.29	20.6	15.49	17.5	47.22	1.5
9305-12-12	1-3/16	1-3/16	15.47	15.47	17.02	17.02	47.24	1.25
9305-12-16	1-3/16	1-7/16	15.47	20.6	17.02	17.5	48.74	1.5
9305-12-20	1-3/16	1-11/16	15.47	26.01	17.02	17.5	50.55	1.75
9305-16-16	1-7/16	1-7/16	20.6	20.6	17.5	17.5	49.25	1.5
9305-16-20	1-7/16	1-11/16	20.6	26.01	17.5	17.5	51.26	1.75
9305-16-24	1-7/16	2	20.6	32	17.5	17.5	53.01	55mm
9305-20-20	1-11/16	1-11/16	26.01	26.01	17.5	17.5	51.26	1.75
9305-24-24	2	2	32	32	17.5	17.5	52.78	55mm

DESIGN DETAILS AND SPECIFICATIONS SUBJECT TO CHANGE WITHOUT PRIOR NOTICE - Whilst every effort has been made to ensure the accuracy of the information supplied herein, Burnett & Hillman cannot be held responsible for any errors or omissions (E&OE)