

All dimensions are imperial unless stated.

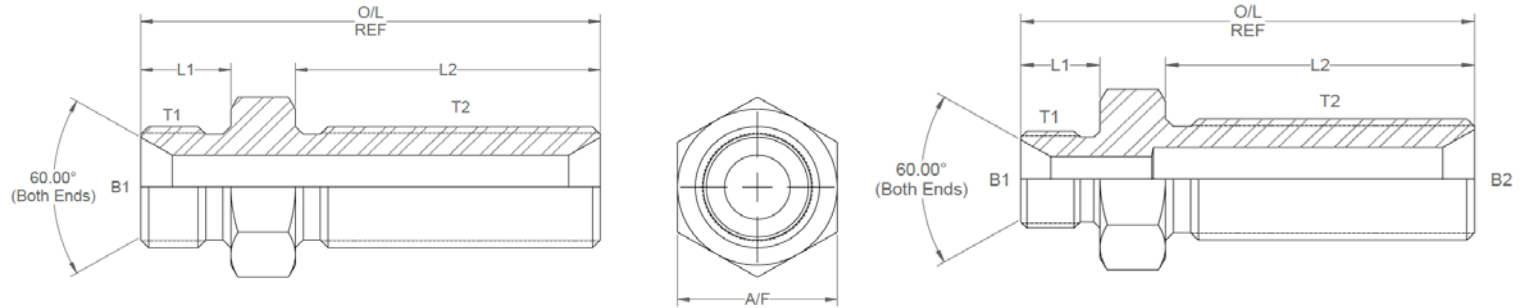

	T1	T2	B1	B2	L1	L2	O/L	A/F
00240	1/4	1/4	0.234		0.45	1.79	2.51	19mm
00241	3/8	3/8	0.312		0.52	1.85	2.72	22mm
00242	1/2	1/2	0.437		0.6	2.03	3.06	27mm
00245	5/8	5/8	0.5		0.7	2.07	3.17	30mm
00243	3/4	3/4	0.625		0.75	2.25	3.33	32mm
00244	1	1	0.875		0.8	2.56	3.89	41mm
00238	1-1/4	1-1/4	1.125		0.8	2.57	3.9	50mm
00246	1-1/2	1-1/2	1.312		0.85	2.57	3.97	55mm
00239	2	2	1.719		1	2.57	4.17	70mm
00248	3/8	1/2	0.312	0.437	0.52	2.03	2.98	27mm
00247	1/2	3/8	0.437	0.312	0.6	1.85	2.88	27mm
00249	3/4	1/2	0.659	0.437	0.75	2.03	3.13	32mm

A/F dimensions are imperial unless stated.

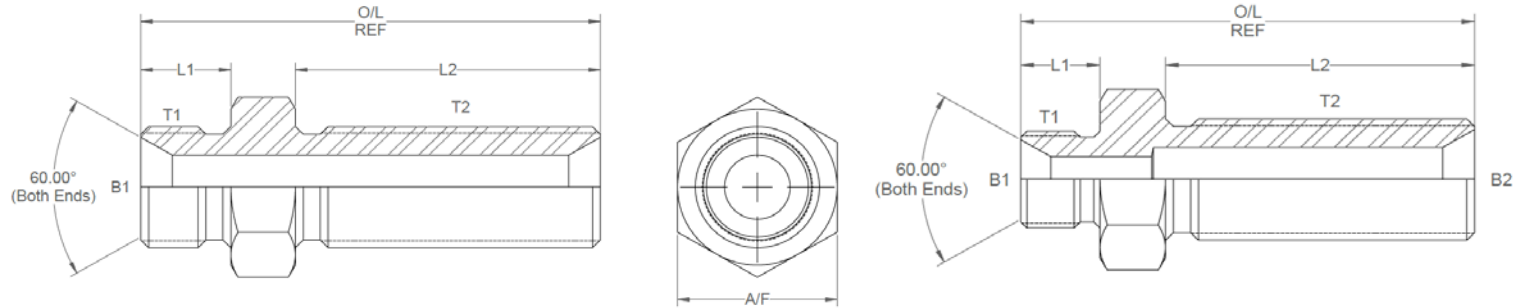

	T1	T2	B1	B2	L1	L2	O/L	A/F
00240	1/4	1/4	5.94		11.43	45.47	63.75	19mm
00241	3/8	3/8	7.92		13.21	46.99	69.09	22mm
00242	1/2	1/2	11.1		15.24	51.56	77.72	27mm
00245	5/8	5/8	12.7		17.78	52.58	80.52	30mm
00243	3/4	3/4	15.88		19.05	57.15	84.58	32mm
00244	1	1	22.23		20.32	65.02	98.81	41mm
00238	1-1/4	1-1/4	28.58		20.32	65.28	99.06	50mm
00246	1-1/2	1-1/2	33.32		21.59	65.28	100.84	55mm
00239	2	2	43.66		25.40	65.28	105.92	70mm
00248	3/8	1/2	7.92	11.10	13.21	51.56	75.69	27mm
00247	1/2	3/8	11.10	7.92	15.24	46.99	73.15	27mm
00249	3/4	1/2	16.74	11.10	19.05	51.56	79.50	32mm